

## Gas-solid Two-phase Flow of Pulverized Coal by ECT: A Review

Nur Arina Hazwani Samsun Zaini<sup>1</sup>, Ruzairi Abdul Rahim<sup>1\*</sup>, Juliza Jamaludin<sup>2</sup>, Herman Wahid<sup>1</sup>, Mimi Faisyalini Ramli<sup>3</sup>, Nasarudin Ahmad<sup>1</sup>, Mohamad Shukri Manaf<sup>1</sup>, Yusri Md. Yunos<sup>1</sup>, Anita Ahmad<sup>1</sup>, Ahmad Azahari Hamzah<sup>5</sup>, Chan Kok San<sup>4</sup>, Farah Aina Jamal Mohamad<sup>1</sup>, Navintiran<sup>1</sup>, Syarfa Najihah Raisin<sup>2</sup>, Fatinah Mohd Rahalim<sup>2</sup>

<sup>1</sup>School of Electrical Engineering, Faculty of Engineering, Universiti Teknologi Malaysia, 81310 UTM Johor Bahru, Johor.

<sup>2</sup>Electronic Engineering Programme, Faculty of Engineering and Built Environment, Universiti Sains Islam Malaysia (USIM), 71800 Negeri Sembilan.

<sup>3</sup>Faculty of Technology Engineering, Universiti Tun Hussein Onn, Campus Pagoh, 84600 Panchor, Johor.

<sup>4</sup>I-Stone Technology Sdn. Bhd, 81400 Senai, Johor.

<sup>5</sup>Section of Chemical Engineering Technology UniKL Micet, 78000Alor Gajah, Melaka.

Corresponding author\* email: ruzairi@fke.utm.my

Accepted 3 March 2021, available online 31 March 2021

### ABSTRACT

Electrical capacitance tomography (ECT) is a non-intrusive and non-invasive internal visualization tool that facilitates improved quantification by producing cross-sectional distribution information for any kind of multiphase flow. In a coal-fired power station, there are some concerning issues such as the sedimentation of pulverized coal in the piping system before it reaches the boiler system and the non-uniformity of its velocity, which contributes to a reduction in electricity generation and higher carbon dioxide emissions. The aim of this paper is to provide a review based on various research works on pulverized coal that utilized ECT system. This paper also consists of principle of ECT, image reconstruction, and velocity measurement. Further research and works will be executed based on the preliminary data gained to improve the existing works.

**Keywords:** Electrical capacitance tomography, pulverized coal, multiphase flow

### 1. Introduction

Coal is the only fossil energy source which can play a significant role as a transformative source of energy as it transitions from the economic system based on oil and natural gas to the future economic system based on non-depletable or sustainable energy systems [1]. Because of its tremendous emissions of acidic contaminants, the coal-fired power plant has been considered a crucial source of regional air pollution and environment acidification [2]. The combustion of fossil fuels produces about 75% of man-made CO<sub>2</sub> pollution. The primary source of CO<sub>2</sub> emissions is the electricity supply market, accounting for about 37 percent of global CO<sub>2</sub> emissions, which will continue to rise in the future [3]. The piping system in coal power plant plays an important role in coal burning process, which can improve the efficiency of coal burning inside the boiler. Unbalanced coal/air flow in coal-fired power plant pipe systems can lead to non-uniform combustion in the furnace, resulting in an overall poorer boiler efficiency [4]. Higher efficiency results in cost savings during the technical lifetime of the plants. The coal sedimentation within the pipe and non-uniform coal velocity during the transition process from pipe to boiler are the key problems with the piping system [5].

Multiphase detectors are critical instruments in the industries for the purpose of tracking and evaluating the behaviour of artefacts in the process system. Multiphase flow in one flow system consists of two or three phases. Gases, liquids and solids have distinct physical properties and travel at different speeds [6]. Within the tuyere of a coal fired power plant, the mechanics of the pulverised coal flow entails complex multi-phase flow phenomenon. It requires the phase of gas and solid particles [7]. ECT offers a more versatile option to discover online flow phenomena non-invasive and non-intrusive. It is also the best method for assessing the output of energy in coal-fired thermal power plants, especially in determining the position of coal sedimentation and pulverised coal velocity. ECT will be the most suitable choice to be used for its mobility and portability of all current tomography methods. Generally, a non-invasive instrument does not invade the wall of the conduit or vessel containing the process medium being examined. The advantages of non-invasive instruments are [8] :

- i. Reduce the hazards when dealing with poisonous, radioactive, explosive, and corrosive materials.
- ii. Minimize the security and accountancy problems with valuable process materials.
- iii. Avoid the exposure of pure or sterile materials.
- iv. Facilitates installation and maintenance process of the instruments even when the plant is on-stream.

## 2. Electrical Capacitance Tomography (ECT)

Electrical Capacitance Tomography (ECT) is a soft-field sensor, which the sensitivity decreases towards the pipe's middle. It detects the variation of permittivity distribution in the closed region or pipe [9]. ECT's fundamental concept is to obtain capacitances and adjustments between electrode pairs and to recreate a cross-sectional picture reflecting the dielectric material concentration and distribution in the region of interest (ROI) [10]. A typical ECT block diagram system consists of ECT sensor, Capacitance measuring unit, Data acquisition system (DAS) and Control computer as shown in Figure 1 below. The ECT sensor consists of a variety of primary measurement electrodes, radial and axial end of screen's ends, an external insulation frame, and a connectors and coaxial cable. Usually the ECT system will consist between 8 or 12 electrodes [9]. ECT has been used in many industrial applications such as dry solids flows, wet gas flows, and gas-liquid flows [11]. Some parameters that need to be considered in electrical capacitance tomography is the diameter of the inner vessel, the thickness of vessel wall, length of probe, and the dielectric constant of probes and vessel. Figure 2 shows the typical or basic ECT system configuration consist of eight-electrode sensors.

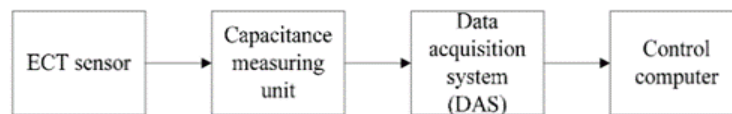

Figure. 1. Block diagram of Electrical Capacitance Tomography (ECT) system [12]

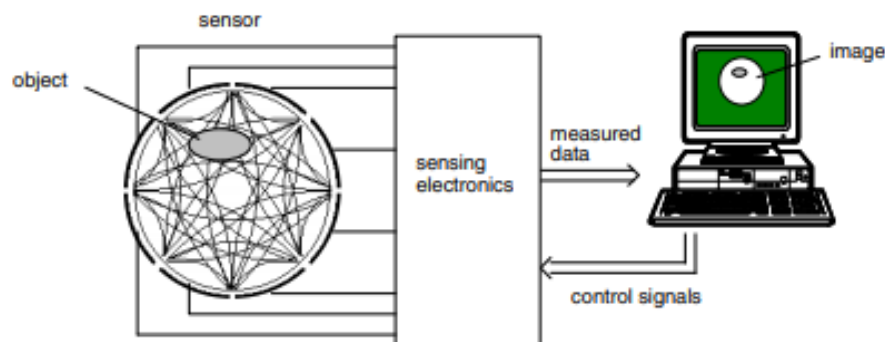

Figure. 2. Typical ECT system configuration consist of eight-electrodes sensors [13]

### 2.1 Principles of ECT

The core principle of the ECT system is to measure the capacitance shifts of the multiple electrode sensor and to utilize the computed capacitance values to recreate the permittivity distribution. In order to visualize the medium located in the pipes or vessel, several electrodes should be arranged along the boundaries of the area. Then, the capacitance between all the combination pairs of the electrodes can be determined. An image can be generated from the data obtained by using any suitable reconstruction algorithm. The basic ECT system can consist a number of 8, 12 or 16 electrodes, a capacitance measurement circuit, a central control unit, and a control PC. The signal conditioning system consist of amplifying circuit, filter circuit, AC to DC converter circuit and capacitance measurement circuit [8]. Figure 3 shows the cross-sectional view of ECT sensor with 16-segmented portable electrodes that was developed by E.J.Mohamad and her teammates.

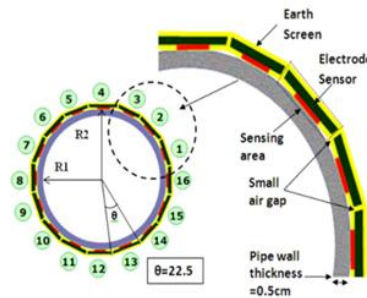

Figure 3. The cross-sectional view of ECT sensor with 16-segmented portable electrodes [14]

Between any two electrodes, the mutual capacitance is determined where one active electrode acts as a transmitter and the other grounded electrodes function as receivers. The number of independent capacitance measurements  $M$  for one distribution is given by [15]:

$$M = \frac{N(N-1)}{2} \quad (1)$$

where  $M$  is the total collected capacitance measurements and  $N$  represents the total electrodes number.

Number of electrodes can affect the parallel data acquisition of the ECT system, but it also depends on the size of the pipe. Small number of electrodes produces a lower parallel data acquisition in which it also effects the quality of the reconstructed image. The higher the value of total collected capacitance measurement, the higher the resolution of the image reconstruction. Higher value of total collected capacitance measurement requires complicated and expensive hardware [16]. There are some criteria that we need to consider in designing ECT sensors by putting the emphasis on four main elements as listed below [17]:

- i. Number of electrodes: smaller number of electrodes will increase the data acquisition rate of the system which elevate the speed of the data acquisition process. It also simplifies the data acquisition system (DAS).  
A larger number of electrodes will operate in vice versa of the smaller number of electrodes. The larger the number of electrodes will enhance the image reconstruction process, but it requires more complicated and costly hardware.
- ii. Earthed screen: to remove outer noise, the outer screen is mandatory, while the axial and radial screen will increase ECT sensor efficiency. There are three types of earthed screens that can be used in ECT sensor: the radial screen, the outer screen and the axial screen.
- iii. Length of electrode: a shorter electrode would yield better dynamic factors. The short electrode is often used to detect small objects and a large bandwidth of the signal, although it often has a 3D effect.
- iv. Guard electrode: this electrode was used to keep the electric field line straight. Inside the vessel, an optimal condition is for single material and essentially applied when the measuring circuit is used for charge-discharge.

## 2.2 Image Reconstruction Technique in ECT

Image reconstruction is the processes used to produce a picture or an image of within a region, from the data obtained on its boundary non-invasively. It is possible to see image reconstruction as the outcome of a statistical inverse problem in which the result is derived from the source. As a result, the methods of measuring and recording developed to generate the images are profoundly dependent on the application that being considered [18]. Coal sedimentation within the pipe and non-uniform coal velocity during the transition process from pipe to boiler can be monitored by trough the final image output from the ECT system. To obtain the final image captured of the measured object in the vessel from different angles and positions, we need to do the image reconstruction. In order to do that, we need to use a suitable image reconstruction algorithm to solve the equation and reconstruct virtual cross section. There have been a variety of recent or related algorithms built to solve the ill posed and ill-conditioned concerns. Generally, the image reconstruction algorithm can be divided into two categories which is non-iterative algorithms and iterative algorithms [13].

i. Non-iterative Algorithms.

Non-iterative algorithms also known as single-step algorithm in which it does not have the repetition of the process. For non-iterative algorithm, the famous and common used algorithms are Linear Back Projection (LBP), Tikhonov regularization, Direct method based on singular value decomposition and multiple linear regression and regularization [13].

ii. Iterative Algorithm.

Iterative algorithms in ECT system are according to the measurement of capacitance values from the current image permittivity distribution. then the generation of a new image using the difference between the capacitance measured and then capacitance value determined. This procedure is replicated until there is a satisfactorily low differences or error to obtain more accurate image output. There are various type of iterative algorithms such as Newton Raphson, iterative Tikhonov approach, Landweber iteration, steepest descent method, algebraic reconstruction technique (ART), and simultaneous iterative reconstruction technique [13]. Iterative algorithm is advantageous as when compared to others, it can be implemented for any geometrical scanning and incomplete data scanning [8].

### 3. Related Works

There are various research work have been done that were related to gas-solid two-phase flow of pulverized coal by implementing the ECT. Those works have been found in literature [19][20][21] will briefly discussed in this section.

In [19], a simulation works were done by implementing ECT sensors for gas-solid two-phase flow. The particular reason for this works is to investigate the image reconstruction performance of a non-iterative algorithm and iterative algorithm to 16 segmented electrodes ECT system by executing simulation works. The generalized vector sampled pattern matching (GVSPM) and Landweber that categorized as iterative algorithm was contrasted with Linear Back Projection (LBP) that known as a non-iterative algorithm for four different categories, which are central flow, annular flow, stratified flow and two circles by percentage error and image correlation evaluation. The simulation process implemented the use of Matlab, COMSOL Multiphysics, and a PC with 8 Gigabytes and Pentium Core-i5. The ECT sensor configuration for the simulation works as shown in figure 4 below.

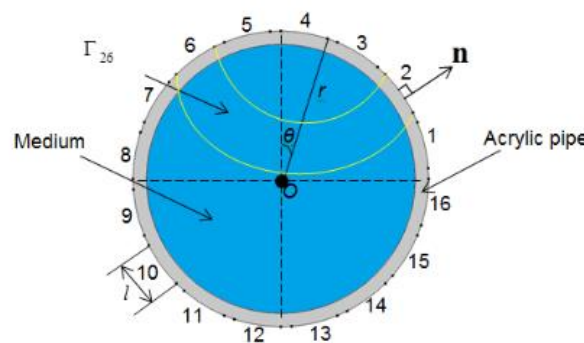

Figure. 4. ECT sensor configuration [19]

The result for the image reconstruction for each phantom condition with different algorithm is shown in figure 5. Landweber algorithm shows the best results compared to others in terms of image accuracy, low percentage error and higher correlation coefficient with acceptable elapsed time. Landweber is the iterative algorithm. The time required to perform each iteration might be too long is one of the critical problems that need to be considered when it involves the implementation of ECT system. It also requires expensive and high-performance PC to simulate the whole image reconstruction process.

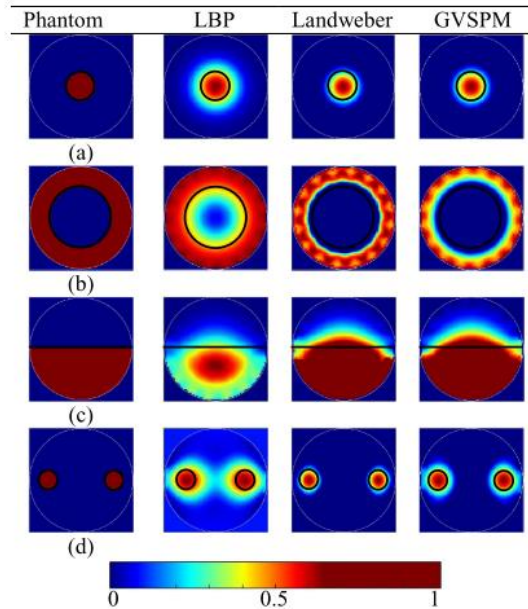

Figure. 5. Image reconstruction result based on simulated data [19]

An experimental bench was introduced by [20] for pneumatic conveying of power at pressurized conditions a mass average diameter of  $69 \mu\text{m}$  and a real density of  $1444 \text{ kg/m}^3$  at a pressure of  $0.84 \text{ MPa}$ . ECT technology was used to generate the cross-sectional images of gas-solid flow in a vessel or pipe flow, while transmitters captured differential pressure at the same time. Consistent with previous definitions of gas-solid flow patterns by Geldart and Pan, the ECT images revealed a full-range flow pattern of horizontal gas-solid pipe flow. This experimental bench uses two sets of 8-electrode ECT sensors. The electrical capacitance tube or vessel design and the hardware connection for the experimental bench is shown in Figure 6 below.

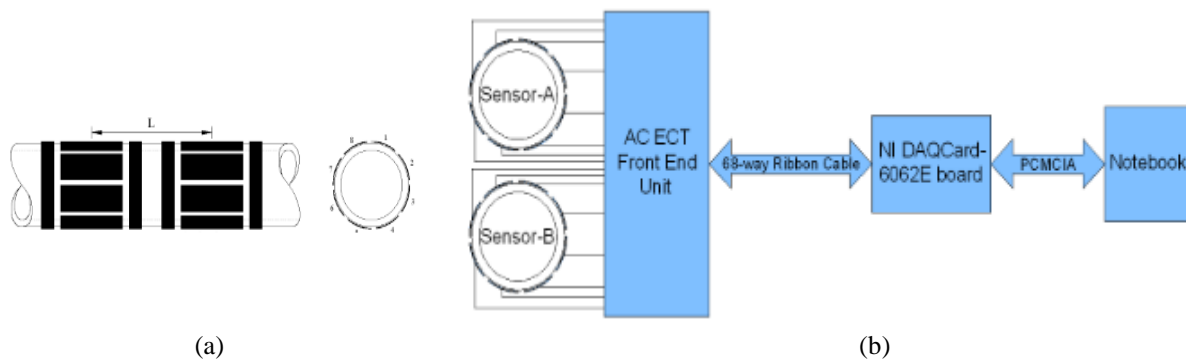

Figure. 6. The figures can be divided into (a) Electrical Capacitance Tomography tube, (b) Hardware connections [20]

Next, the experimental studies done by [21] to measure and visualize the concentration of pulverized coal by implementing the ECT sensors. To minimize processing time, an algorithm called an OIOR (offline iteration and online reconstruction) image reconstruction algorithm has been used in the experimental process to estimate the volumetric concentration measurement of the solid. OIOR executed in two stages the offline process and online process consecutively. Cross-correlation reliability is based on the distance between the ECT sensors and the data acquisition measurement frequencies. It was used to measure the velocity of the solid flow of the pulverized coal. The flow velocity measurement by implementing the cross-correlation is illustrated in figure 7 below. Figure 8 shows the experimental setup for gas-solid mass flow measurement.

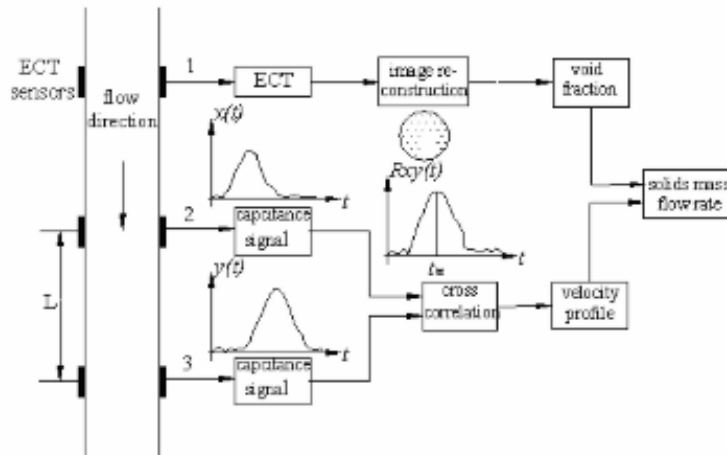

Figure. 7. The illustration of flow velocity measurement using cross-correlation [21]

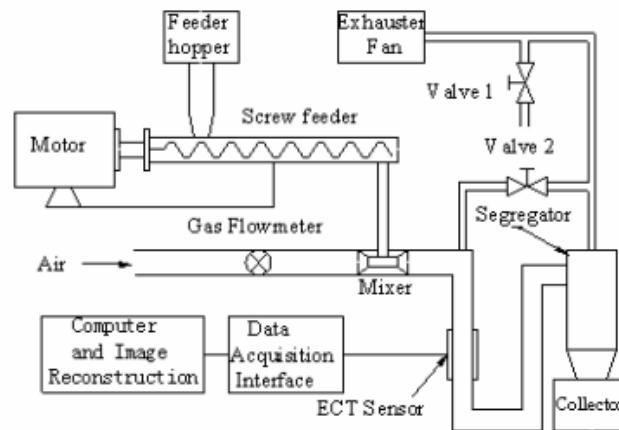

Figure. 8. The experimental setup for gas-solid mass flow measurement [21]

Figure 9 shows the result for solids distribution in cross-section at the upstream sensor for different times. From the images, we can sum up that the distribution in cross-section is variable every time.

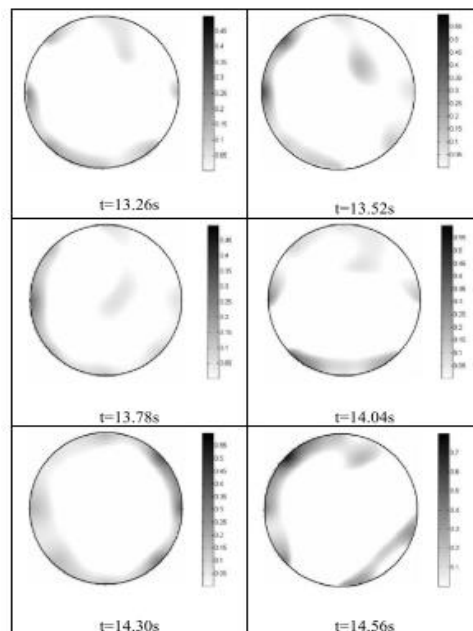

Figure. 9. Solid distribution cross-section [21]

## 4. Conclusion

To summarize all that has been stated so far, the mass flow calculation of pneumatically distributed solids has been of great interest to many industrial organizations and academic institutions worldwide. ECT system has been applied in many multiphase flow monitoring because of the non-invasive and non-intrusive characteristic of the system. Online monitoring of the concentration of pulverized fuel would lead to an increase in the performance and stability of combustion and a decrease in carbon emission and corrosion in the combustion chamber. In gas-solid two-phase flow of pulverized coal, we also need to consider the pressure and the temperature.

This paper provides the review of the related works that emphasizes on gas-solid two-phase flow of pulverized coal. It also explained the principles of ECT system, Image reconstruction techniques and some related works. Simulation process is important in designing any systems to produce a higher performance system.

## Acknowledgment

The authors would like to thank to Universiti Teknologi Malaysia for supporting the research study under UTMER Reseach Fund, vot number QJ130000.3851.19J61.

## References

- [1] Balat, H. (2007). Role of coal in sustainable energy development. *Energy Exploration and Exploitation*, 151–174.
- [2] Zhao, Y., Wang, S., Duan, L., Lei, Y., Cao, P., & Hao, J. (2008). Primary air pollutant emissions of coal-fired power plants in China: Current status and future prediction. *Atmospheric Environment*, 42(36), 8442–8452.
- [3] Mathieu, P. (2006). *The IPCC special report on carbon dioxide capture and storage*.
- [4] Vijiapurapu, S., Cui, J., & Munukutla, S. (2006). CFD application for coal/air balancing in power plants. *Applied mathematical modelling*, 30(9), 854–866.
- [5] A. Azahari *et al.*, (2020). *Status Confirmation For Doctoral Thesis Characterization Of Gas-Solid Two-Phase Flow By Using Electrical Capacitance Tomography*. Degree of Doctor of Philosophy in Electrical Engineering . Faculty of Electric and Electronic Engineering, Universiti Tun Hussein Onn.
- [6] Michaelides, E. (2006). *Particles, bubbles & drops: their motion, heat and mass transfer*. World Scientific.
- [7] Chen, C. W. (2005). Numerical analysis for the multi-phase flow of pulverized coal injection inside blast furnace tuyere. *Applied Mathematical Modelling*, 29(9), 871-884.
- [8] Rahim, R. A. (2011). *Electrical Capacitance Tomography: Principles, Techniques and Applications*. Penerbit UTM Press.
- [9] Rahman, N. A. A., Rahim, R. A., Nawi, A. M., Ling, L. P., Puspanathan, J., Mohamad, E. J., & Yunus, F. R. M. (2015). A review on electrical capacitance tomography sensor development. *Jurnal Teknologi*, 73(3).
- [10] Cui, Z., Wang, H., & Yin, W. (2015). Electrical capacitance tomography with differential sensor. *IEEE Sensors Journal*, 15(9), 5087–5094.
- [11] Hunt, A. (2014). Weighing without touching: Applying electrical capacitance tomography to mass flowrate measurement in multiphase flows. *Measurement and Control*, 47(1), 19–25.
- [12] Johana, E., Yunus, F. R. M. & RAHIM R. A. (2011). *View\_of\_Hardware\_Development\_Of\_Electrical\_Capacitance\_Tomography.pdf*.
- [13] Y. Li, S. Cao, Z. Man, and H. Chi, (2011). Image reconstruction algorithm for electrical capacitance tomography,” *Inf. Technol. J.*, 10(8), 1614–1619.
- [14] Mohamad, E. J., Rahim, R. A., Rahiman, M. H. F., Ameran, H. L. M., Muji, S. Z. M., & Marwah, O. M. F. (2016). Measurement and analysis of water/oil multiphase flow using Electrical Capacitance Tomography sensor. *Flow Measurement and Instrumentation*, 47, 62–70.
- [15] Deabes, W., Sheta, A., Bouazza, K. E., & Abdelrahman, M. (2019). Application of electrical capacitance tomography for imaging conductive materials in industrial processes. *Journal of Sensors*, 2019.
- [16] Rahman, N. A. A., Rahim, R. A., Nawi, A. M., Ling, L. P., Puspanathan, J., Mohamad, E. J., ... & Yunus, F. R. M. (2015). A review on electrical capacitance tomography sensor development. *Jurnal Teknologi*, 73(3).
- [17] Yang, W. (2006). Key issues in designing capacitance tomography sensors. In *Sensors, 2006 IEEE* (497–505). IEEE.
- [18] Moscoso, M. (2008). Introduction to image reconstruction. In *Inverse Problems and Imaging* (1–16). Springer, Berlin, Heidelberg.

- [19] Rahim, R. A., Hamzah, A. A., Mohamad, E. J., Puspanathan, J., Kadir, K. A., & Ameran, H. L. M. (2018). Simulation Studies on Image Reconstruction Algorithm for Portable Electrical Capacitance Tomography. *International Journal of Integrated Engineering*, 10(8).
- [20] Guan, Q., Wang, W., & Zhang, J. (2011). Flow patterns of pneumatic conveying of pulverized coal in horizontal pipes for pressurized conditions. In 2011 Asia-Pacific Power and Energy Engineering Conference (1–4). IEEE.
- [21] Liu, J., Sun, M., Wang, X. Y., & Liu, S. (2010). Experiment Investigation on Concentration and Mass Flow Measurement of Pulverized Coal Using Electrical Capacitance Tomography. In *AIP Conference Proceedings*, 1207(1), 252–257.