

# Advancing Strain Gauge Technology: Design, Integration, and Industrial Applications

Muhammad Hafizi Mohd Diah<sup>1</sup>, Muhammad Haziq Faris Sahli Hazimin<sup>1</sup>, Herlina Abdul Rahim<sup>1\*</sup>, Nur Athirah Syafiqah Noramli<sup>2</sup>, Aisyah Mohd Akram<sup>3</sup>

<sup>1</sup>Faculty of Electrical Engineering, Universiti Teknologi Malaysia, 81310 Skudai, Johor, Malaysia

<sup>2</sup>School of Electrical Engineering, College of Engineering, Universiti Teknologi MARA, Shah Alam, Selangor

<sup>3</sup>Regional Development & Strategy, Siemens Energy, Cyberjaya, Selangor

Corresponding author\* email: herlina@utm.my

Available online 30 June 2025

## ABSTRACT

This paper presents a comprehensive exploration of strain gauge sensor technology within the realm of industrial instrumentation. Strain gauges play a critical role in accurately measuring material deformation across a wide range of industrial applications. The study delves into the various types of strain gauges, their operational principles, technical specifications, and application scenarios. It also covers sensor interfacing techniques, microcontroller programming, circuit analysis, and proposes potential innovations for next-generation sensors. Through detailed analysis, simulations, and implementation strategies, this work aims to equip engineers and researchers with a deep understanding of strain gauge systems and their significance in industrial environments. Additionally, it provides a foundation for optimizing sensor performance and encourages future developments in sensor technology.

**Keywords:** Instrumentation, Microcontroller, Sensor, Strain Gauge, Principal Operation.

## 1. Introduction

In 1938 Edward E. Simmons and writer C. Ruge invented the strain gauges [1]. A metallic foil is supported by an insulating flexible backing that consists of a strain gauge. When a force is applied, a strain gauge is used as a sensor for measuring variations in resistance, then converting those changes in electrical resistance into measurements. A strain gauge is a sensor that translates force, pressure, tension, weight, etc. into a change in electrical resistance that can subsequently be measured [2]-[4].

The foundation of industrial instrumentation rests upon the intricate designs and varied structures of strain gauge sensors. This section unveils the nuances of each strain gauge type, providing insight into their unique structures tailored for specific applications. From measuring weight in load cells to ensuring the structural integrity of critical infrastructure, strain gauge sensors play a pivotal role across industries. Besides, this section explores the diverse applications, showcasing the versatility of these sensors in industrial settings. At the heart of understanding strain gauge sensors lies the examination of their datasheets. This section unravels the critical information encapsulated within, from material specifications to temperature ranges, providing engineers and researchers with the essential details needed for effective utilization.

## 2. Background

Strain gauges manifest in various types and structures, each tailored for specific applications. The primary categories include:

- (i) Bonded Foil Strain Gauge - This strain gauge is characterized by a thin metallic foil bonded to a flexible backing material. It is well-suited for static and dynamic measurements due to its high sensitivity.
- (ii) Wire-wound Strain Gauge - Comprises a wire wound around a core and encapsulated in a protective coating. It is notable for its durability and capacity to withstand harsh environmental conditions.
- (iii) Semiconductor Strain Gauge - The semiconductor strain gauge utilizes semiconductor materials for strain measurement. Known for high sensitivity and applicability in space-constrained scenarios.

(iv) Thin-film Strain Gauge - This strain gauge involves the deposition of a thin layer of conductive material on the surface. Ideal for applications requiring a low-profile sensor.

Strain gauge sensors are essential parts of many different applications and are woven across a wide range of industrial environments. Load cells with strain gauges are used in weighing apparatus in manufacturing and logistics to guarantee accurate readings on scales and industrial balances. Strain gauges are used by structural health monitoring systems to evaluate the structural integrity of buildings, pipelines, and bridges. Strain gauges play a vital role in the stress analysis of automotive industry components, including suspension systems, chassis, and brake systems. Strain gauge sensors are used in aircraft wings and structural components in aerospace applications for ongoing safety evaluation and monitoring. This part explores the wide range of uses, demonstrating the adaptability of strain gauge sensors in a variety of real-world machinery in many sectors.

An indispensable aspect of understanding strain gauge sensors is a meticulous examination of their datasheets, which encapsulate critical information such as:

- (i) Material specifications of the strain gauge.
- (ii) Temperature range within which accurate measurements are ensured.
- (iii) Sensitivity values for different types.

This foundational knowledge, acquired through the exploration of types, applications, and datasheets, serves as a robust framework for engineers and researchers aiming to leverage strain gauge sensors effectively in their industrial applications.

**Table 1.** Specifications between three types of Strain Gauge series [3]

Specification	BF Series	BA Series	ZF Series
nominal resistance ( $\Omega$ )	350,650,1000	350,650,1000	350,650,1000
tolerance of resistance	$<\pm 0.1\%$	$<\pm 0.1\%$	$<\pm 0.1\%$
gauge factor	2.00 – 2.20	1.86 – 2.20	1.86 – 2.40
gauge factor resistance	$<\pm 1\%$	$<\pm 1\%$	$<\pm 1\%$
strain limit	2.00%	2.00%	2.00%
fatigue life	$>10^7$	$>10^7$	$>10^7$
effective modulus compensation	not available	not available	aluminum (23)
metal foil	constantan alloy	constantan alloy	karma alloy
creep compensation	available	available	available
working temperature range	$-30\pm 80^\circ\text{C}$	$-30\pm 150^\circ\text{C}$	$-30\pm 80^\circ\text{C}$
temperature compensation	Titanium (9), steel alloy (11), stainless steel (16), aluminum (23)		
curing temperature	135°C (curing process) 165°C (post curing process)		

Based on Figure 1, some of the critical information such as gauge materials and temperature range have been given inside the specifications. Besides the sensitivity value can be determined indirectly from inverse the given nominal resistance value. To determine the right intended functional strain gauge, the name code and material dimensions must be meticulously observed as per visualized in Figure 1 and Figure 2 respectively.

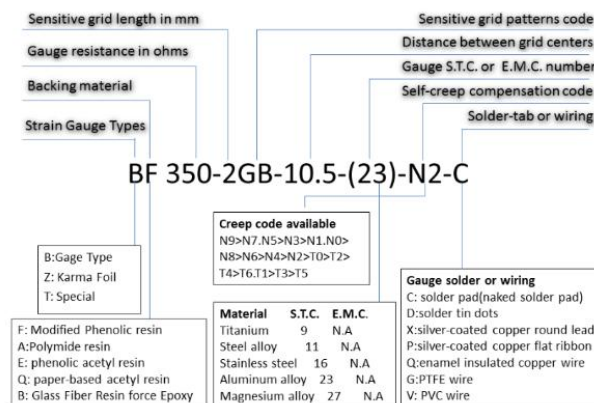

**Figure 1.** Products labeling name code [1]

AA linear strain gages	MODEL	GRID DIM		BACKING DIM		CREEP
		L (mm)	W (mm)	L (mm)	W (mm)	
	BF120-1AA(**)	1.0	3.14	4.7	4.0	
	BF120-3AA(**)	3.0	2.44	6.6	3.4	
	BF175-3AA(**)	3.0	2.6	6.6	3.6	
	BF350-1AA(**)	1.0	3.75	4.6	4.7	
	BF350-1.5AA(**)	1.7	3.85	4.8	4.7	
	BF350-2AA(**)	2.1	3.4	5.1	4.2	
	BF350-3AA(**)	3.2	3.1	7.3	4.1	
	BF350-4AA(**)	4.1	3.1	8.2	4.1	
	BF350-5AA(**)	5.0	2.9	9.3	3.9	
	BF350-6AA(**)	6.0	2.9	10.3	3.0	
	BF500-3AA(**)	3.0	3.6	7.3	4.6	
	BF1000-1.5AA(**)	1.7	4.2	5.0	5.0	
	BF1000-2AA(**)	2.1	4.0	5.1	5.0	
	BF1000-3AA(**)	3.15	3.7	6.9	4.6	
	BF2000-3AA(**)	3.0	4.2	6.6	5.0	

Figure 2. Products dimension [1]

### 3. Technical Characteristics

#### 3.1 Static Characteristics

Strain gauge sensors possess a suite of technical characteristics that collectively define their performance. In the realm of static characteristics, sensitivity stands out as a key metric, indicating the sensor's responsiveness to minute changes in strain. Expressed in macrostrains per unit strain, a higher sensitivity enhances the sensor's ability to detect subtle deformations. Accuracy, another critical static characteristic, gauges how closely the sensor's readings align with actual values. Precision is the marker of repeatability, ensuring that strain gauge sensors consistently produce similar results under identical conditions. Linearity, integral for accurate readings, ensures that the sensor's response maintains a proportional relationship with the applied strain, minimizing deviations.

#### 3.2 Dynamic Characteristics

Dynamic characteristics, on the other hand, focus on the sensor's responsiveness to changes over time. Response time, a dynamic metric, measures how swiftly the strain gauge reacts to alterations in the applied strain. Strain gauges excel in providing fast response times, making them apt for dynamic measurements where rapid changes need to be captured. Bandwidth, the range of frequencies over which the sensor operates accurately, is a dynamic characteristic influenced by the strain gauge's design. High resolution, indicative of a sensor's ability to detect small variations in input, is crucial for applications requiring precision. Finally, low hysteresis, a dynamic characteristic, ensures consistent and repeatable measurements during dynamic loading and unloading conditions. These technical characteristics collectively empower strain gauge sensors to deliver reliable, accurate, and responsive measurements across a spectrum of industrial applications.

### 4. Working Principle

The theory behind how a strain gauge operates is the change in electrical resistance brought on by mechanical strain. A tiny wire or foil, usually composed of a highly conductive substance like copper or constantan, is bonded to a flexible backing material to form the strain gauge as shown in Figure 3 [3]. The length and cross-sectional area of the wire or foil vary because of deformation that occurs when mechanical strain is applied to the strain gauge. The wire or foil's electrical resistance varies in proportion to this change in size.

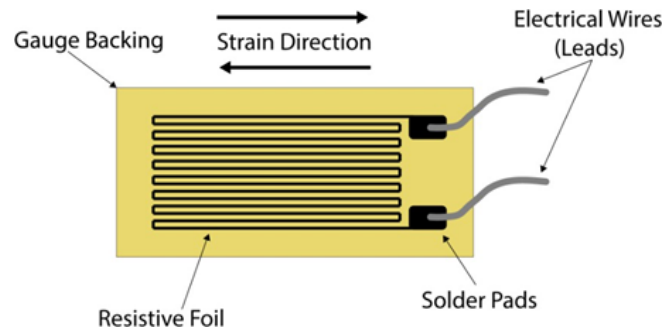

**Figure 3.** Construction of Strain Gauge [3]

Using a Wheatstone bridge circuit as in Figure 4, which is frequently used in strain gauge applications, the change in resistance may be detected [3]. The strain gauge is one of the four resistive arms that make up the Wheatstone bridge. Usually, the remaining three arms are made of fixed resistors. An imbalance in the Wheatstone bridge circuit results from a strain on the strain gauge, which causes a change in the gauge's resistance. A little electrical output signal that is proportionate to the applied strain is produced by this imbalance. There are several configurations for the Wheatstone Bridge circuit, such as a full bridge with four active gauges, a half bridge with two gauges, or a quarter bridge, which is less frequent. Precision resistors complete the bridge in the half and quarter circuits.

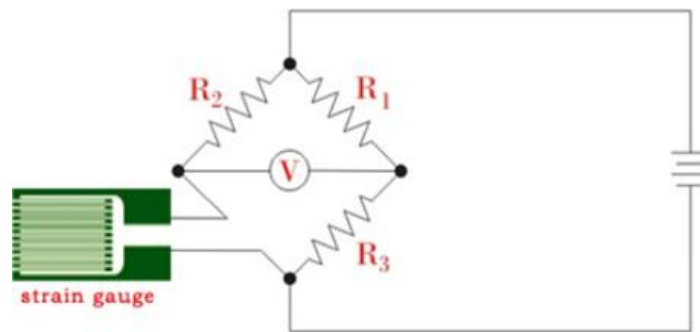

**Figure 4.** Wheatstone Bridge of Strain Gauge [3]

It is possible to calculate the strain's magnitude by monitoring the output signal. This makes it possible to analyze a variety of mechanical characteristics, including stress, load, and deformation in structural elements. Applications for strain gauges are widely used in the fields of material testing, aerospace, automotive, and civil engineering. The sections that follow will provide further information on its uses in civil engineering.

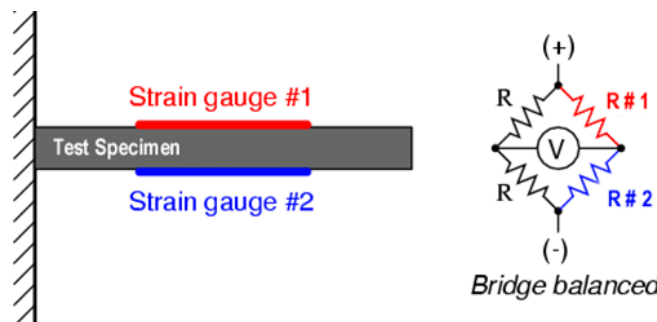

**Figure 5.** Half Bridge Bond Pair Strain Gauge

Figure 5 illustrates one possible method of bonding a pair of strain gauges to a test specimen [5-6]. The bridge circuit is balanced, and both strain gauges have equal resistance when the test specimen is not subjected to force. Nevertheless, the specimen will bend downward as shown in Figure 6 when a downward force is applied to its free end, simultaneously compressing gauge #2 and extending gauge #1.

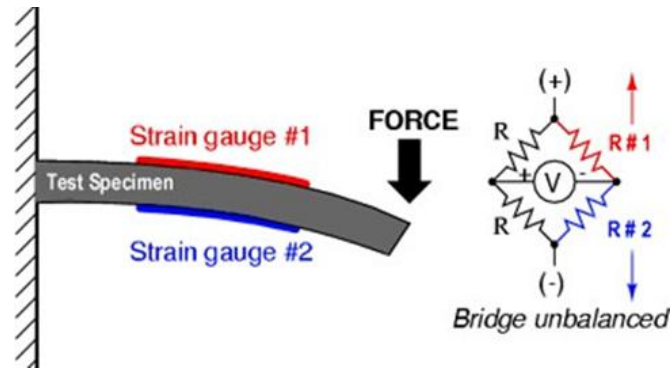

Figure 6. Downward force of on the Strain Gauge

## 5. Connection with Other Instruments

For the simulation part, Proteus was used as platform to simulate the strain gauge application. The application that chosen for the strain gauge to work as a device is load cell. Load cell is a complete sensor or transducer designed to measure force or load. It typically includes one or more strain gauges as part of its construction.

A strain gauge load cell measures force or weight by utilizing the principle of strain. It consists of a metallic structure with one or more strain gauges attached to it. When a force is applied to the load cell, the material deforms slightly, causing the strain gauges to experience a change in electrical resistance. This change in resistance is proportional to the amount of deformation, and therefore, to the applied force. The load cell is designed and calibrated in such a way that the electrical signal produced by the strain gauges accurately reflects the force or weight being applied [7-11]. By measuring this electrical signal, typically through a Wheatstone bridge circuit, the load cell provides an output that can be converted into a precise measurement of the force or weight exerted on it.

### 5.1 Wiring Samples

Based on Figure 7, for the load cell application, Arduino Uno was used as microcontroller for this device. The HX711 was added into this circuit because the HX711 is a precision analog-to-digital converter (ADC) specifically designed for amplifying and digitizing small signals, making it well-suited for use in conjunction with load cells. In load cell applications, the HX711 plays a crucial role in converting the minute electrical signals generated by the strain gauges in the load cell into digital data that can be easily processed by a microcontroller or computer. It features a built-in programmable gain amplifier, which allows for adjusting the amplification of the signal based on the specific characteristics of the load cell. Additionally, the HX711 has a high level of precision and noise reduction capabilities, contributing to accurate and stable measurements in weight and force sensing applications.

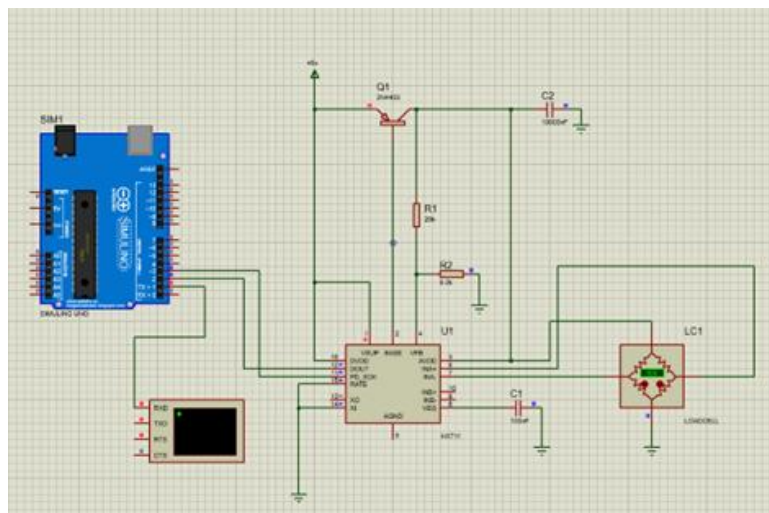

Figure 7. Connection of the Load Cell

The resistor and capacitor were also added into the circuit. In load cell signal conditioning circuits, a resistor is often employed as a pull-up or pull-down resistor in digital communication interfaces like Serial Peripheral Interface (SPI) to define default voltage levels. Concurrently, a capacitor is commonly integrated as part of a low-pass filter to minimize high-frequency noise and stabilize the analog signal from the load cell. Together, these components contribute to ensuring a well-defined, stable, and noise-resistant signal for accurate measurements, particularly when interfacing with analog-to-digital converters like the HX711.

### 5.2 Coding Explanations

For coding explanations, this Arduino program utilizes the HX711 library to interface with a load cell, providing weight measurements in kilograms. The load cell is connected to pins 2 (D<sub>OUT</sub>) and 3 (SCK) on the Arduino. The script initializes the HX711 scale, performs initial readings from the ADC, and then sets up the scale with a calibration factor. The calibration factor is determined by known weights and is used to convert raw ADC readings to weight values. The program then enters the main loop, repeatedly printing the weight in kilograms, both as a single measurement and as an average of 10 readings. The delay of 5000 milliseconds (5 seconds) between readings allows for stability in the measurements. This script demonstrates the basic setup and operation of a load cell using the HX711 library for weight measurements on an Arduino platform.

Illustrate the load cell simulation with weights of 2, 4, 6, and 8 kg, as depicted in Figure 8. Simulate the load cell response to these weights to see its performance and calibration in converting raw readings to corresponding weight values.

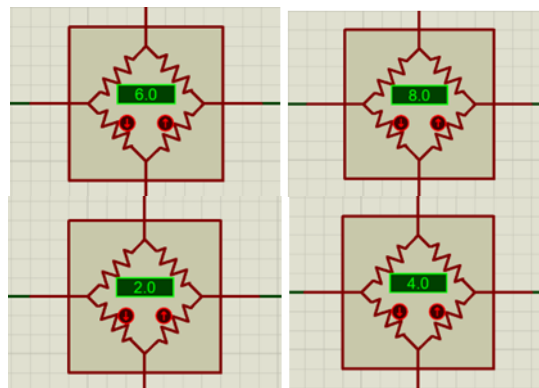

Figure 8. The illustration weight put on the load cell

The output data after the simulation. The data showing its coming from the illustration weight that had been given based on Figure 9.

```
Virtual Terminal
HX711 Demo
Initializing the scale
Before setting up the scale:
read: 6.00
read average: 6.00
get value: 6.00
get units: 6.0
After setting up the scale:
read: 6.00
read average: 6.00
get value: 0.00
get units: 0.0
Readings:
Weight in KG:0.0| average:0.00000
Weight in KG:2.0| average:2000.00012
Weight in KG:4.0| average:4000.02807
Weight in KG:6.0| average:6000.05566
Weight in KG:8.0| average:8000.05615
```

Figure 9. Data simulation on the virtual terminal

## 6. Creating Another Type of Device

With the existing component used by the load cell, it can be created another device, a tilt sensor. By utilizing a strain gauge in a Wheatstone bridge configuration, the sensor becomes sensitive to changes in inclination, translating them into variations in electrical resistance. The HX711, acting as an amplifier, facilitates the conversion of these subtle changes

into a readable digital signal for the Arduino. Incorporating a transistor allows for efficient power management, ensuring that the strain gauge is activated only when necessary, optimizing energy consumption. The capacitor contributes to signal stability. This tilt sensor can find application in diverse scenarios, serving as a leveling tool, tilt alarm, or angle indicator for platforms. The versatility and simplicity of this project make it an accessible and educational endeavor for those exploring sensor creation with common electronic components and an Arduino platform.

## 7. Conclusion

Finally, this comprehensive research digs into the complex world of strain gauge sensors, exploring their various varieties, uses, technical properties, operating principles, and interactions with other devices. The analysis of datasheets and a practical application in load cell simulations highlight the sensor's critical role in industrial instrumentation. The work also broadens its scope by demonstrating how strain gauges can be used to create alternative devices, such as a tilt sensor. This research is a great resource to refer to for further research about strain gauge.

## References

- [1] Wikipedia. Strain gauge [Internet]. [cited 2024 Jan 28]. Available from: [https://en.wikipedia.org/wiki/Strain\\_gauge](https://en.wikipedia.org/wiki/Strain_gauge).
- [2] Omega. Strain gauges [Internet]. [cited 2024 Jan 11]. Available from: <https://sea.omega.com/my/prodinfo/straingages.html>.
- [3] Kai Siren, Gunnar Rosén, János Vad, Peter V. Nielsen, 12 - Experimental Techniques, Editor(s): Howard Goodfellow, Esko Tähti, Industrial Ventilation Design Guidebook, *Academic Press*, pp: 1105-1195. 2001. <https://doi.org/10.1016/B978-012289676-7/50015-1>.
- [4] Boiron, T., Aubourg, C., Grignard, P.-A. & Callot, J.-P. The clay fabric of shales is a strain gauge. *J. Struct. Geol.* Vol. 138, pp 104 – 130, 2020. <https://doi.org/10.1016/j.jsg.2020.104130>.
- [5] Ștefănescu, D.M. “Strain sensitivity as selection criterion for elastic elements of force transducers: A brief review”. *Sens. Actuators A Phys.* 315, pp. 112 – 238, 2020. <https://doi.org/10.1016/j.sna.2020.112238>.
- [6] El-Gamal, S. “Effect of strain on the I–V characteristics of discontinuous silver films and determination of their gauge factor”. *J. Mater. Sci. Mater. Electron.* 24(11), pp. 4311–4315, 2013. <https://doi.org/10.1007/s10854-013-1403-z>.
- [7] Ellis, B.L. & Smith, L.M. “Modeling and experimental testing of strain gauges in operational and failure modes”. *IEEE Trans. Instrum. Meas.* 58(7), pp. 2222–2227, 2009. <https://doi.org/10.1109/TIM.2009.2013672>.
- [8] Tilak, V., Jiang, J., Batoni, A. & Knobloch, “A. GaN based high temperature strain gauges”. *J. Mater. Sci. Mater. Electron.* 19, pp.195–198, 2008. <https://doi.org/10.1007/s10854-007-9331-4>.
- [9] Bingger, P., Zens, M. & Woias, “P. Highly flexible capacitive strain gauge for continuous long-term blood pressure monitoring”. *Biomed Microdevices.* 14(3), pp. 573–581, 2012. <https://doi.org/10.1007/s10544-012-9636-9>.
- [10] Nag, A., Afasrimanesh, N., Feng, S. & Mukhopadhyay, “S.C. Strain induced graphite/PDMS sensors for biomedical applications”. *Sens. Actuators A Phys.* 271, pp. 257–269, 2018. <https://doi.org/10.1016/j.sna.2018.01.044>.
- [11] Arshak, K., Morris, D., Arshak, A. & Korostynska, O. “Development of high sensitivity oxide based strain gauges and pressure sensors”. *J. Mater. Sci. Mater. Electron.* 17(9), pp. 767–778 (September 2006). <https://doi.org/10.1007/s10854-006-0013-4>.